

pic. 1

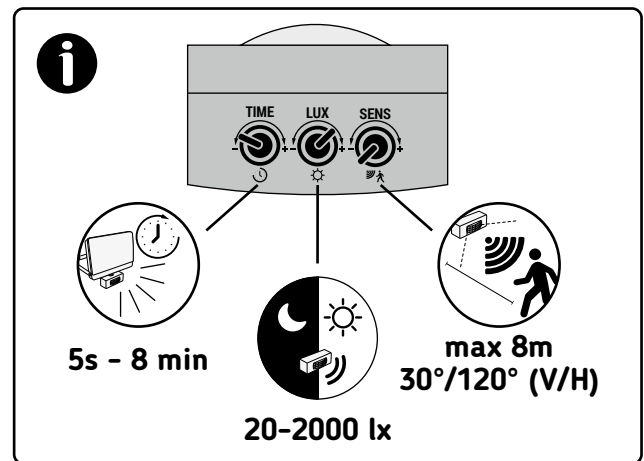

4 → 2 B, A

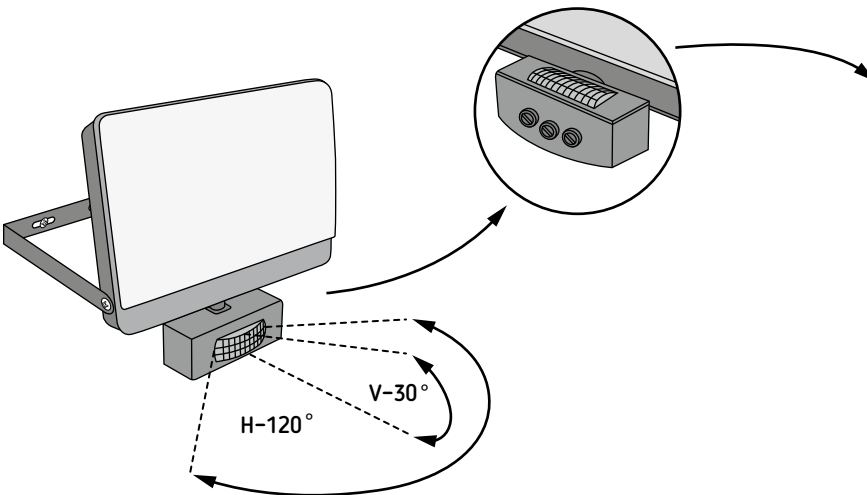
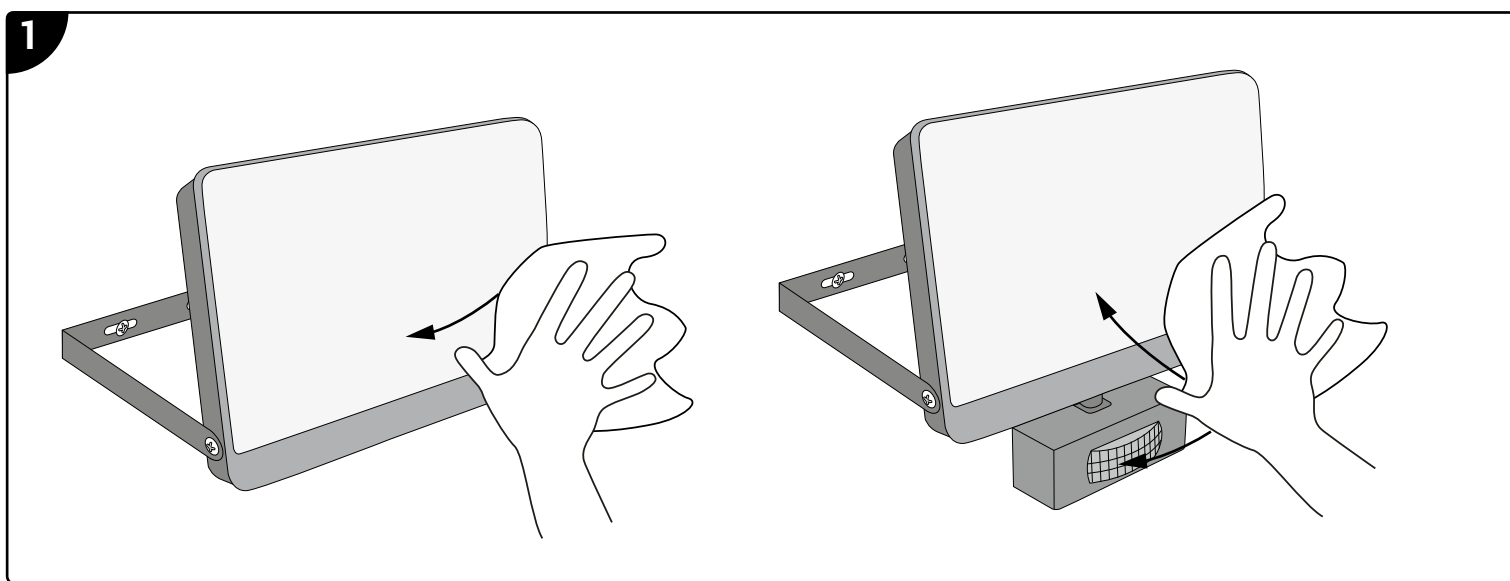
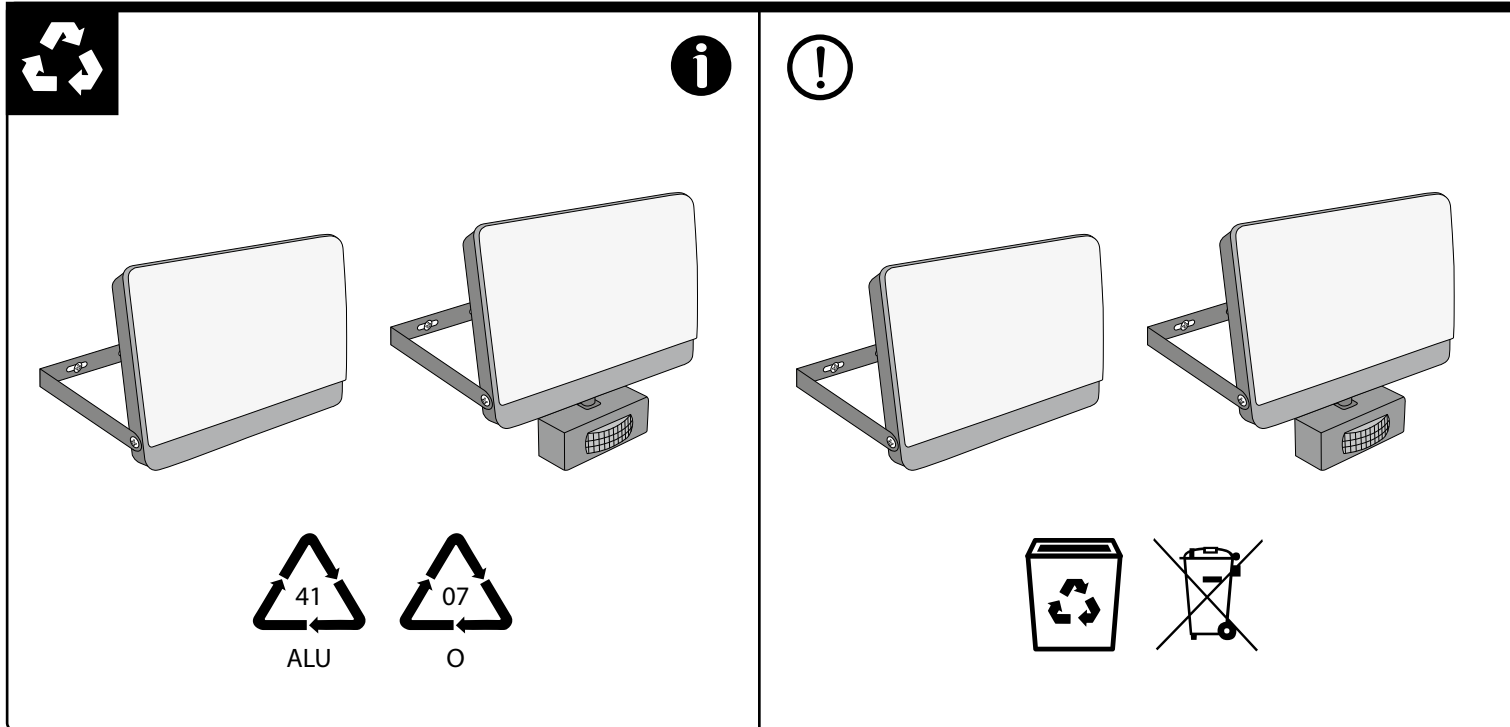

STRÜHM	PN-EN 60598-2-5:2016-02-5.5.	b) Kg	b) Y (mm)	b) X (mm)	b) Z (mm)	c) m ²
04243	BRYZA LED 15W BLACK NW	0,21	85	125	35	0,011
04244	BRYZA LED 30W BLACK NW	0,34	120	170	35	0,020
04245	BRYZA LED 50W BLACK NW	0,52	150	210	39	0,032
04246	BRYZA LED S 15W BLACK NW	0,24	130	125	40	0,016
04247	BRYZA LED S 30W BLACK NW	0,38	165	170	40	0,028
04248	BRYZA LED S 50W BLACK NW	0,56	195	210	40	0,041